

Signature Series

Maximum Resilience Broadcast Audio



U2B Quick Start Guide

Unbalanced to Balanced Converters

U2B 2,4&8 : 1,2&4 Stereo Channel Converters



USER MANUAL



Full User Manual Can Be Downloaded From:

www.glen sound.co.uk/Manuals/Signature/U2B Manual.pdf



THIS UNIT MUST BE EARTHED

AUDIO BLOCK DIAGRAM:

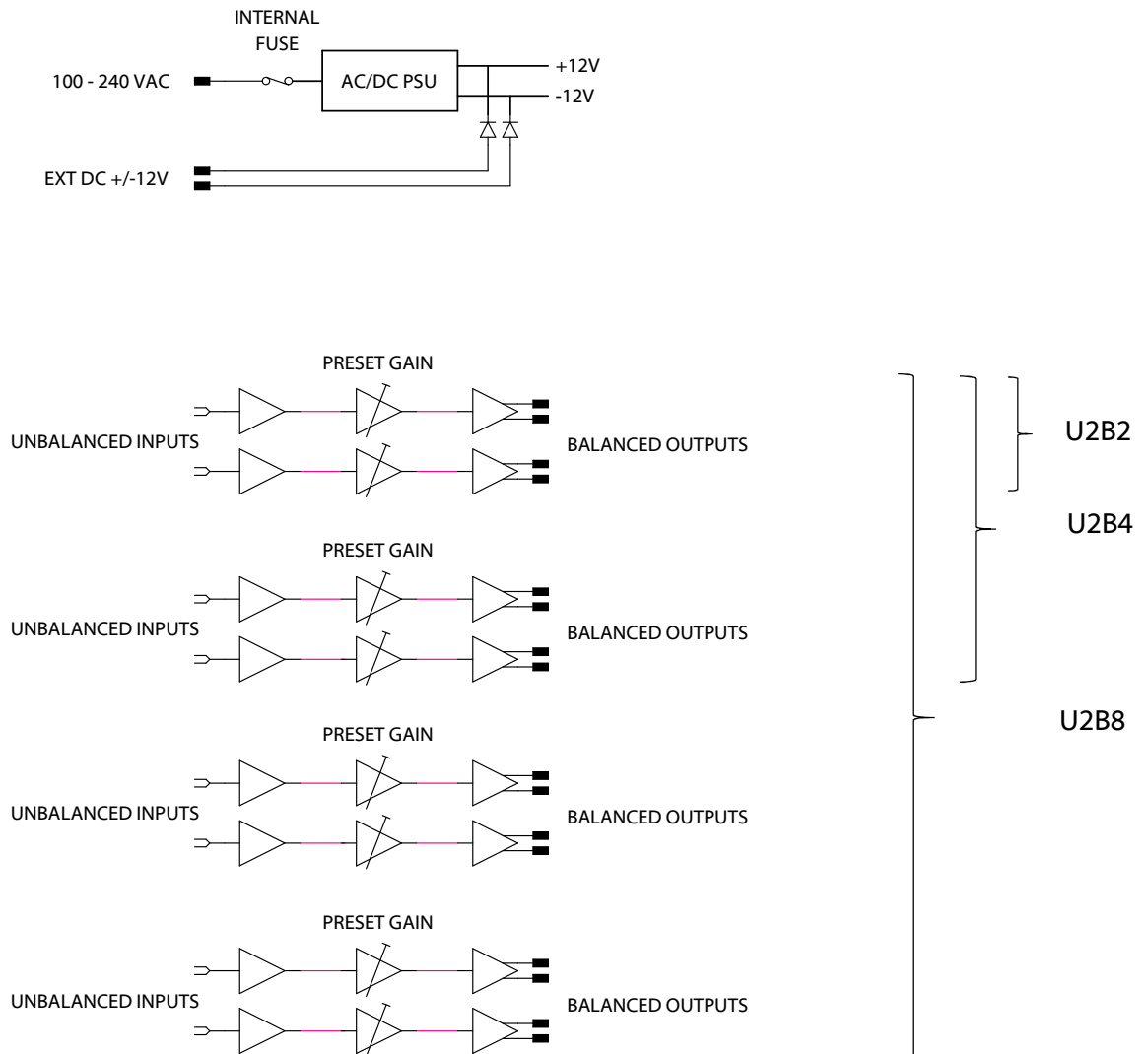

USER CONTROLS

1. POWER ON LED



2. UNBALANCED STEREO INPUT 1

4. UNBALANCED STEREO INPUT 2

3. BALANCED STEREO OUTPUT 1

5. BALANCED STEREO OUTPUT 2



6. INPUT 1 GAIN/LOSS

7. INPUT 2 GAIN/LOSS

8. EXTERNAL DC IN

9. AC MAINS INPUT

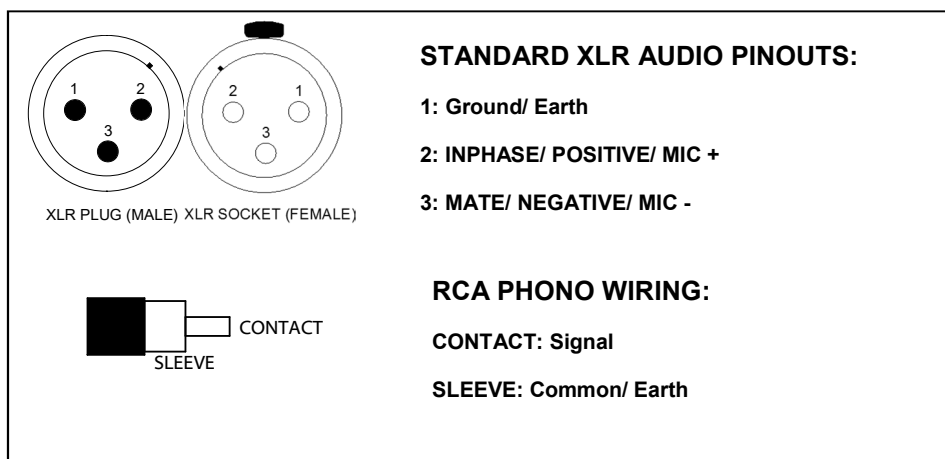

GlenSound
 6 Brooks Place, Maidstone
 Kent, UK, ME14 1HE
 Tel: +44 (0)1622 753662
www.glenSound.co.uk

